



Multi-Loader



optional with wheels

ML 350 E



Multi-Loader ML 350 E

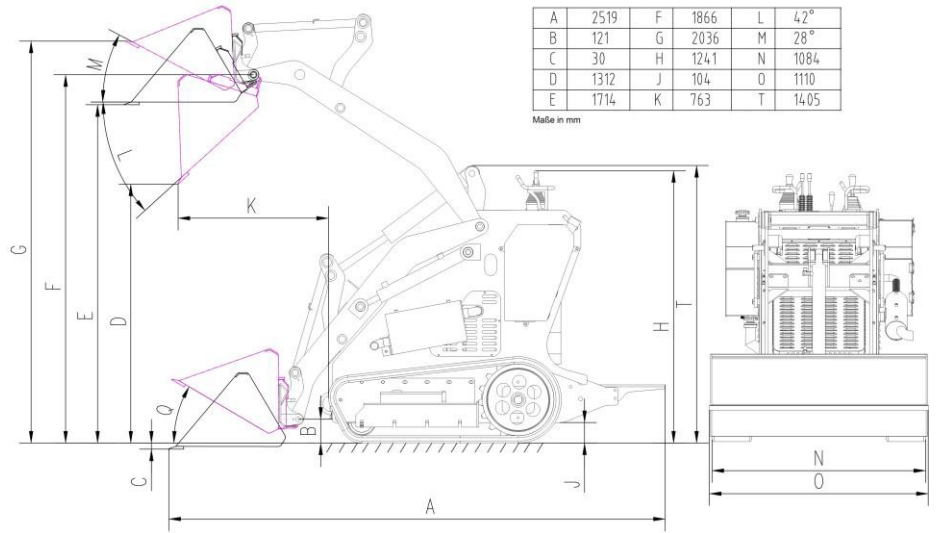
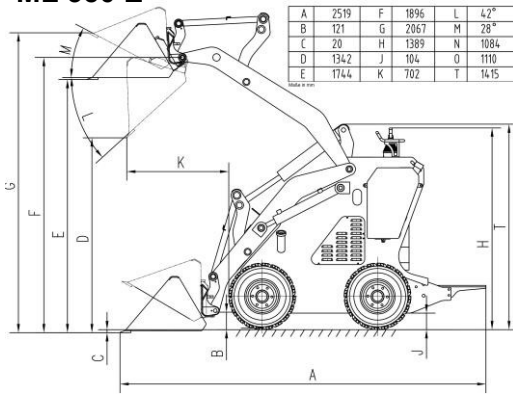

Technical Details

| | |
|--------------------------|---|
| Motor | |
| Honda | GX 690 |
| Type | 2 Cyl. / 4-stroke |
| Displacement | 688 cm ³ |
| Engine Output | 18.4 kW (25.0 HP) |
| Revolution Speed | 3600 rpm |
| Starter | Electric Starter |
| Air Filter | Dry Cartridge |
| Fuel Filter | Sieve |
| Drive | Hydrostatic |
| Guidance | Hydraulic Motor |
| Multi-valve Block | Hydrocontrol |
| Hydraulic pump | Permco |
| Characteristic | Quick-change system joystick control, electric start |



| | |
|----------------------------|----------------|
| Operating Data | |
| Weight Without Attachments | 850 kg |
| Operating Payload | 350 kg |
| Operating Weight (loaded) | 1200 kg |
| Tipping Device | Hydraulic |
| Climbing Ability | Max. 20° (36%) |
| Working Speed | 0 – 5 km/h |
| Oil Pressure | 180 bar |
| Oil Flow Rate | 24.6 ltr./min. |

| | |
|--------------------|--|
| Attachments | 4 in 1 bucket, attachment excavators, pallet fork, gripper, auger, sweeper, trencher, hydraulic breaker/hammer |
|--------------------|--|

Authorized Dealer:



orders@gnhardscape.com
www.greatnorthhardscape.com
1.800.720.7627